

# 東芝照明器具配光データシート

名称	蛍光灯器具
形名	FHR-43576K-PA9

光源	名称	蛍光ランプ
	形名	FHF32EX-N-H
	光束	4950 lm × 3

前面	カバー (プリズム)
反射面	塗装 (白)

保守率	良	0.69
	中	0.65
	否	0.61

効率	F	0%
	F	65%
	F	65%
	器具光束	9689 lm

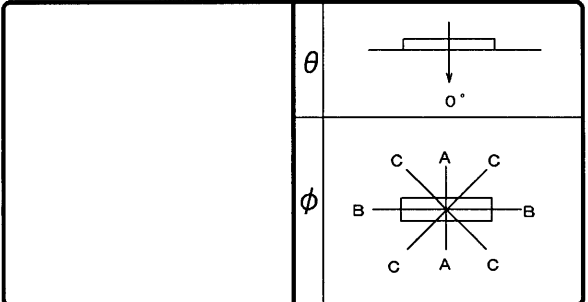

最大取付間隔	
A-A	1.2 H
B-B	1.2 H

備考

θ	φ		
	A-A	B-B	C-C
0°	288	288	288
10°	278	285	286
20°	267	270	273
30°	235	240	244
40°	189	192	191
50°	125	129	123
60°	77	79	64
70°	37	38	27
80°	17	17	17
90°	0	0	0
100°	0	0	0
110°	0	0	0
120°	0	0	0
130°	0	0	0
140°	0	0	0
150°	0	0	0
160°	0	0	0
170°	0	0	0
180°	0	0	0

反射率 (%)	天井		80						70						50						30		20		0			
	壁	床	70	50	30	70	50	30	70	50	30	50	30	30	10	30	10	30	10	30	10	30	10	10	0	10	0	
室指数	照明率 (×0.01)																											
0.60	44	41	36	34	31	30	43	40	35	34	30	29	34	33	30	29	29	29	26	25								
0.80	53	48	44	41	39	37	51	47	43	41	38	37	42	40	38	36	37	36	33	32								
1.00	57	51	49	45	43	41	55	50	48	45	43	41	46	44	42	40	41	40	37	36								
1.25	62	55	54	50	49	45	60	54	53	49	48	45	51	48	47	45	45	44	41	40								
1.50	65	57	58	52	52	49	63	56	56	52	51	48	54	51	50	48	48	47	44	43								
2.00	70	61	64	57	59	54	68	60	62	56	58	53	59	55	55	52	54	52	49	48								
2.50	72	62	67	59	62	56	70	62	65	58	61	56	62	57	59	55	56	54	52	51								
3.00	74	64	70	61	66	58	72	63	68	60	64	58	64	59	61	57	59	56	54	53								
4.00	77	66	73	63	70	61	74	65	71	63	68	61	67	61	65	60	61	59	57	56								
5.00	79	66	75	65	72	63	76	66	73	64	70	62	69	63	67	61	63	60	59	57								
10.00	82	68	80	67	78	66	79	68	77	67	76	66	72	65	71	64	67	63	62	61								

